Clarke[®]

EZ-8

**Drum
Sander**

Section II

Parts and Service Manual

(70754A)

Clarke®
EZ-8 Sander
Assembly Drawing #1 11/01

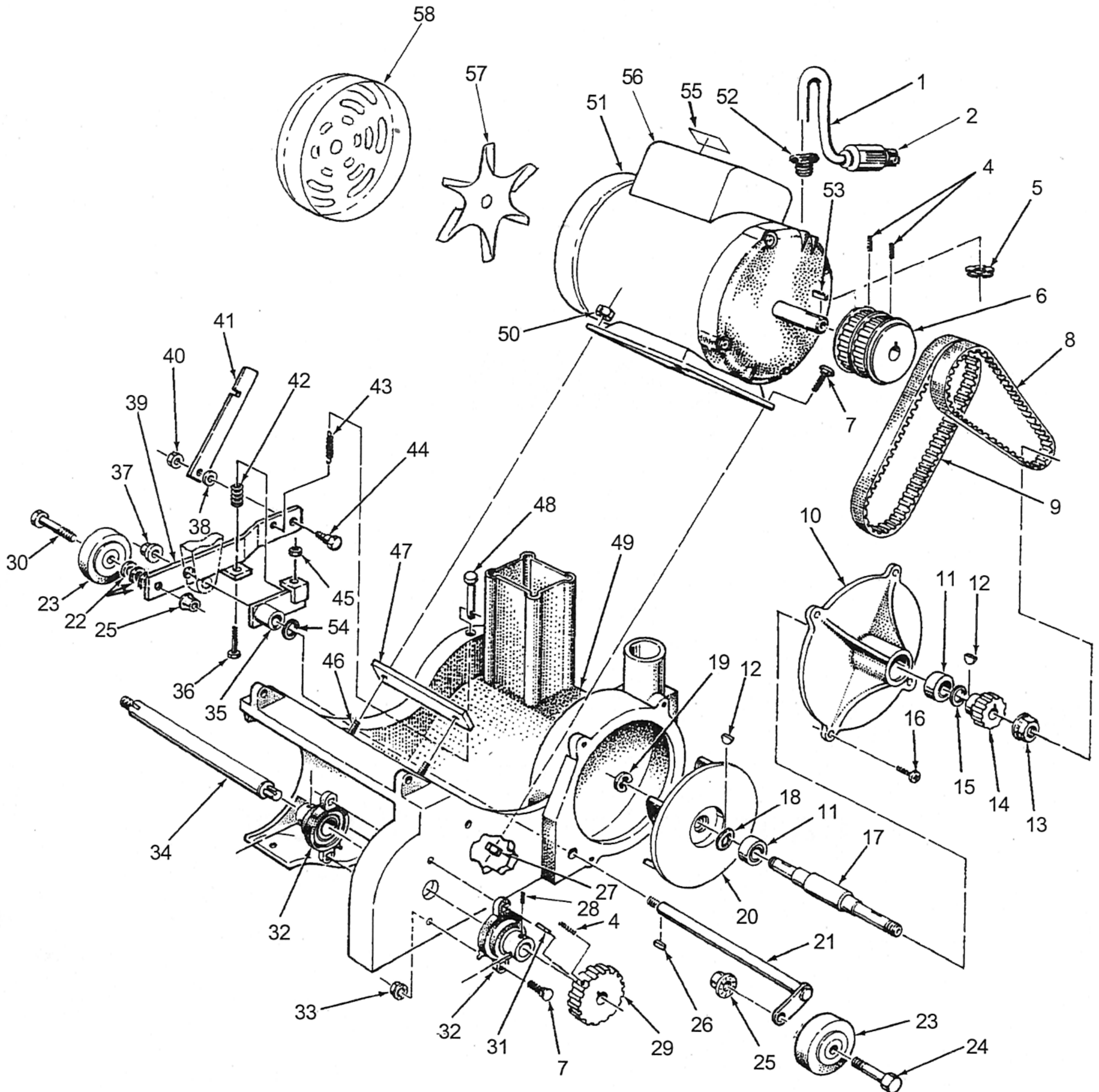

Clarke®
EZ-8 Sander
Assembly Drawing #1 7/03

Ref. #	Part No.	Description	Qty
1	40542A	Cord, Motor	1
2	45602A	Plug L6-15P	1
4	962831	Screw Set 10-32 x 5/16	3
5	170686	Nut Conduit 1/2	1
6	61089A	Pulley, Fan/Drum	1
7	80027A	Screw 5/16-18x1 Sq. Neck	6
8	50917A	Belt, Fan	1
9	50916A	Belt, Drum	1
10	22122A	Cover, Fan	1
11	902567	Bearing	2
12	915561	Key, Hardened	2
13	920196	Nut 1/2-13 Jam	1
14	66159A	Pulley, Fan	1
15	167312	Ring, Retaining	1
16	962798	Screw 10-24 x 1/2	3
17	67457A	Shaft, Fan	1
18	980681	Washer, Bowed	1
19	877307	Ring, Retaining	1
20	65005A	Impeller	1
21	60166A	Axle, Truck	1
22	980648	Spacer	3
23	59945A	Wheel	2
24	86113A	Screw 1/2-13 x 2	1
25	920365	Nut 1/2 - 13 Nylock	2
26	80501A	Key 3/16 x 1 1/4	1
27	81211A	Nut, Flanged 5/16-18	2
28	962689	Screw Set 1/4-28 x 1/4	4
29	66161A	Pulley, Drum	1
30	86114A	Screw 1/2-13 x 2 1/2	1

Ref. #	Part No.	Description	Qty
31	915082	Key 3/16 x 3/16 x 3/4	1
32	51178A	Bearing, Arbor	2
33	81211A	Nut, Flanged 5/16-18	4
34	67459A	Shaft, Arbor Clamp	1
35	60434A	Arm, Truck Level	1
36	85835A	Screw 1/4-20x 2 1/2	1
37	920196	Nut, 1/2-13 Jam	1
38	980645	Washer 3/8 SAE	2
39	60435A	Arm, Truck, Lift	1
40	920110	Nut 5/16-18 ESNA	1
41	65707A	Link Adjust	1
42	58698A	Spring, Truck Leveling 1	
43	58699A	Spring, Drum, Pressure	1
44	80026A	Bolt, Shoulder 3/8 x 1/2	1
45	920284	Nut 1/4 ESNA	1
46	68015A	Stud	2
47	69031A	Spacer, Shim	1
48	82504A	Pin, Clevis 5/16 x 3/4	1
49	25903A	Frame, Main	1
50	81208A	Nut Flanged 5/16-24	2
51	44642A	Motor, 1.5Hp 115V/60Hz	1
	44648A	Motor, 1.5 Hp 230V/50Hz	1
52	170637	Relief, Strain	1
53	915580	Key 3/16 x 1 1/2	1
54	57423A	Ring, Retaining	1
55	77234A	Label, Lifting Warning	1
56	51095A	Cover, Capacitor	1
57	40545A	Fan	1
58	52465A	Cover, Fan	1

Motor Parts Not Illustrated

Motor 44642A			Motor 44648A		
Part No.	Description	Qty	Part No.	Description	Qty
41306A	Capacitor Run	1	41308A	Capacitor Run	1
41307A	Capacitor Start	1	41309A	Capacitor Start	1
47390A	Starter Switch (Cubical)	1	47392A	Thermal Switch	1
47409A	Starter Switch (Cylindrical)	1			
47391A	Thermal Switch	1			

Clarke®
EZ-8 Sander
Assembly Drawing #2 2/07

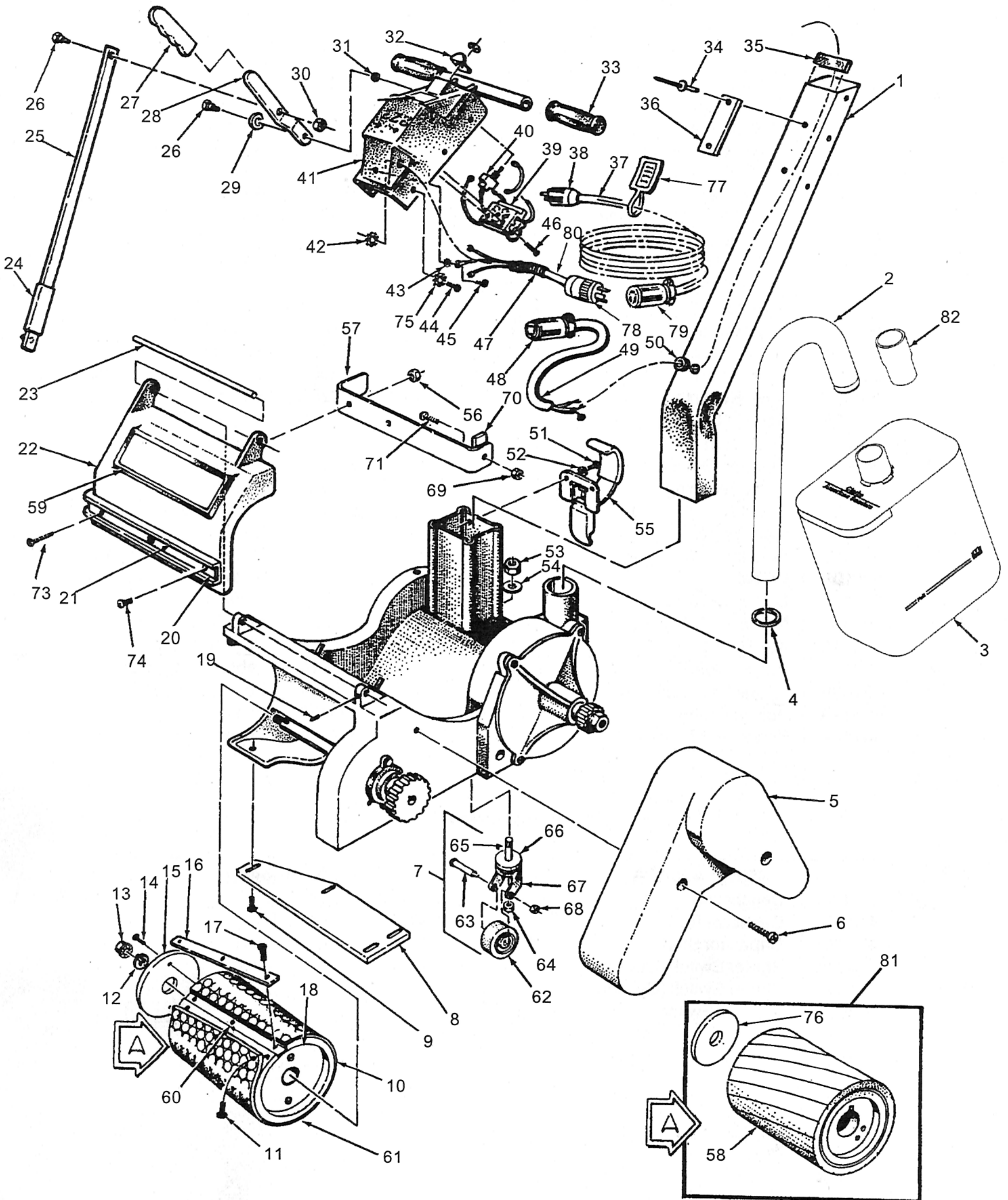

Clarke®
EZ-8 Sander
Assembly Parts List #2 2/07

Ref. #	Part No.	Description	Qty
1	69106A	Tube, Handle	1
2◆	61897A	Tube, Dust	1
3◆	53741A	Bag, Dust	1
4	68285A	Support Tube	1
5	23807A	Guard, Belt	1
6	962988	Screw 1/4-20 x 1 1/4	2
7	52125A	Caster Asm. Complete	1
8	67612A	Shoe, Dust	1
9	962826	Screw 10-24 x 3/8	4
10	32364A	Cover, Drum	1
11	962823	Screw 1/4-20x1/2	13
12	65310A	Key, Washer	1
13	920365	Nut 1/2 - 13 Nylock	3
14	85313C	Screw 6-32 x 3/8	4
15	68613A	Plate, End	1
16	162007	Clamp, Paper	1
17	962733	Screw 12-24 x 1	3
18	62711A	Drum, Clamp Style	1
19	962170	Screw Set 10-24 x 1/4	1
20	66948A	Retainer, Bumper	1
21	31223A	Bumper, Front	1
22	22123A	Cover, Front	1
23	64469A	Handle, Front	1
24	61659A	Collar	1
25	65706A	Link, Control	1
26	960952	Bolt, Shoulder 3/8x3/8	2
27	34609A	Grip, Lever	1
28	65618A	Lever, control	1
29	980022	Washer, Wave	1
30	920110	Nut 5/16-18 ESNA	1
31	980645	Washer 3/8 SAE	2
32	63928A	Guard, Switch	1
33	34610A	Grip, Handle	2
34	930093	Rivet 1/8	2
35	97100A	Trim, Vinyl, Black	Ref
36	74052A	Plate Safety	1
37	40540A	Cord Set, Power 115V	1
38	911248	Plug 5-15P	1
39	41807A	Contactor	1
40	47387A	Switch, Control	1
41	24525A	Housing Control	1
42	81210A	Nut, Fixture 3/8 PT	1

Ref. #	Part No.	Description	Qty
43	980675	Washer	1
44	962677	Screw 10-24 x 3/4	6
45	962826	Screw 10-24 x 3/8	1
46	962109	Screw 10-24 x 5/8	2
47	337504	Relief, Strain	1
48	41708A	Adapter L6 -15R	1
49	40543A	Cord, Interconnect	1
50	51523A	Relief, Strain	1
51	962094	Screw 1/4-20 x 3/8	2
52	170892	Washer, 1/4 Lock	2
53	920196	Nut, 1/2-13 Jam	1
54	980648	Washer 1/2	1
55	55711A	Latch	1
56*	920296	Nut #10 ESNA	2
57*	69098A	Wear, Strip	1
58*	21011A	Drum Expansion	1
	10806A	Recondition Expander	
		Drum, Complete	1
59	70488A	Logo	1
60	65103A	Insert	3
61	13507A	Asm., Drum, Clamp includes 10, 18, 11, 14, 15, 16, 17, & 60	1
62	59960A	Wheel Caster	1
63	80012A	Bolt, Shoulder 5/16 x 1 1/2	1
64	81307A	Nut, 7/16 -14 Jam	1
65	67468A	Shaft, Caster	1
66	51194B	Bearing, Caster	2
67	29405A	Yoke, Caster	1
68	920284	Nut, 1/4-20 ESNA	1
69*	81217A	Nut, 1/4-20 x .218H Nylk.	2
70*	60906A	Block, Wear	2
71*	962505	Screw, 1/4-20 x 5/8	2
72*	77299A	Label, Caution	1
73*	85381A	Screw, 10-24 x 3/4 PN-SB	2
74	85517A	Screw, 10-24 x 1/2 PN-SB	5
74*	85517A	Screw, 10-24 x 1/2 PN-SB	3
75	980603	Washer, #10 Lock Ext. Th.	1
76*	68651A	Plate Drum End	2
77	70175A	Tag Warning	1
78	912169	Plug	1
79	911461	Connector	1
80	40541A	Adapter Cord	1
81*	65311A	Kit, Drum Asm. Expanding	1
82	30563A	Adapter, 2" to 1 1/2"	1

*NOTE: Equipped on sleeve units only

NOTE: ◆ indicates a change has been made since the last publication of this manual.

Accessories Available:

13509A- Three hole-paper clamp bar, packaged with three clamp screws

Clarke®
EZ-8 Sander
Wiring Diagram 11/01

